

TONISCO[®] B30

DN40 (1 1/2") - DN200 (8") Hot tapplings



DH

DC

HVAC

PROCESS

Description



The lightweight and robust TONISCO B30 Hot Tap Machine Set is designed for making connections to pipelines, tanks, and plant piping.

By using the TONISCO B30 Hot Tap Machine Set it is possible to make new connections from DN40 (1 1/2") - DN200 (8"). All the connections can be made without stopping the flow in the main up to 60 bars (900PSI).

The TONISCO B30 Hot Tap Machine is versatile and easy to operate. With suitable adapters TONISCO B30 can be used for flanged, threaded, or weldable connections.

All TONISCO B30 Hot Tap Machines provide an effective and ecological way of making connections to mains for repairs, relocations, or additions.

Features

The TONISCO B30 Hot Tap Machine can be used in max. 200°C (390°F) and in pressure up to 60 bar (900PSI). This TONISCO B30 Hot Tap Machine Set is equipped with an electric drive unit, flanged and threaded adapters.

TONISCO B30 Hot Tap Machine weighs 15,5kg and it can be operated by one person. TONISCO B30 Hot Tap Machine can be used with a wide range of hole saws, pilot drills, and adapters to fit all main materials and substances.

By using TONISCO B30 Hot Tap Machine it is possible to make pipeline alterations without shutdowns.





TONISCO B30 HOT TAPPING SYSTEM SPECIFICATIONS



Technical Specifications

Hot Tapping Range	DN40-DN200 (1 ½" – 8")
Drive Unit Options	<ul style="list-style-type: none"> • Electric 220-240v / 50-60 Hz 1300W • Pneumatic 6-7bar / 1500 l/min • Hydraulic 15-30l/min 140 bar • Manual
Body Material	S355J2 (Hardened)
Feed Unit Material	S355J2
Sealings	EPDM (NBR & VITON)
Testing	Pressure test and construction inspection
Pressure Test	60bar (90bar with high pressure model)
Max. Operational Pressure	40bar (60bar with high pressure model)
Max. Operational Temperature	-40°C to +100°C

TONISCO B30 HOT TAP MACHINE - TYPICAL SET UP

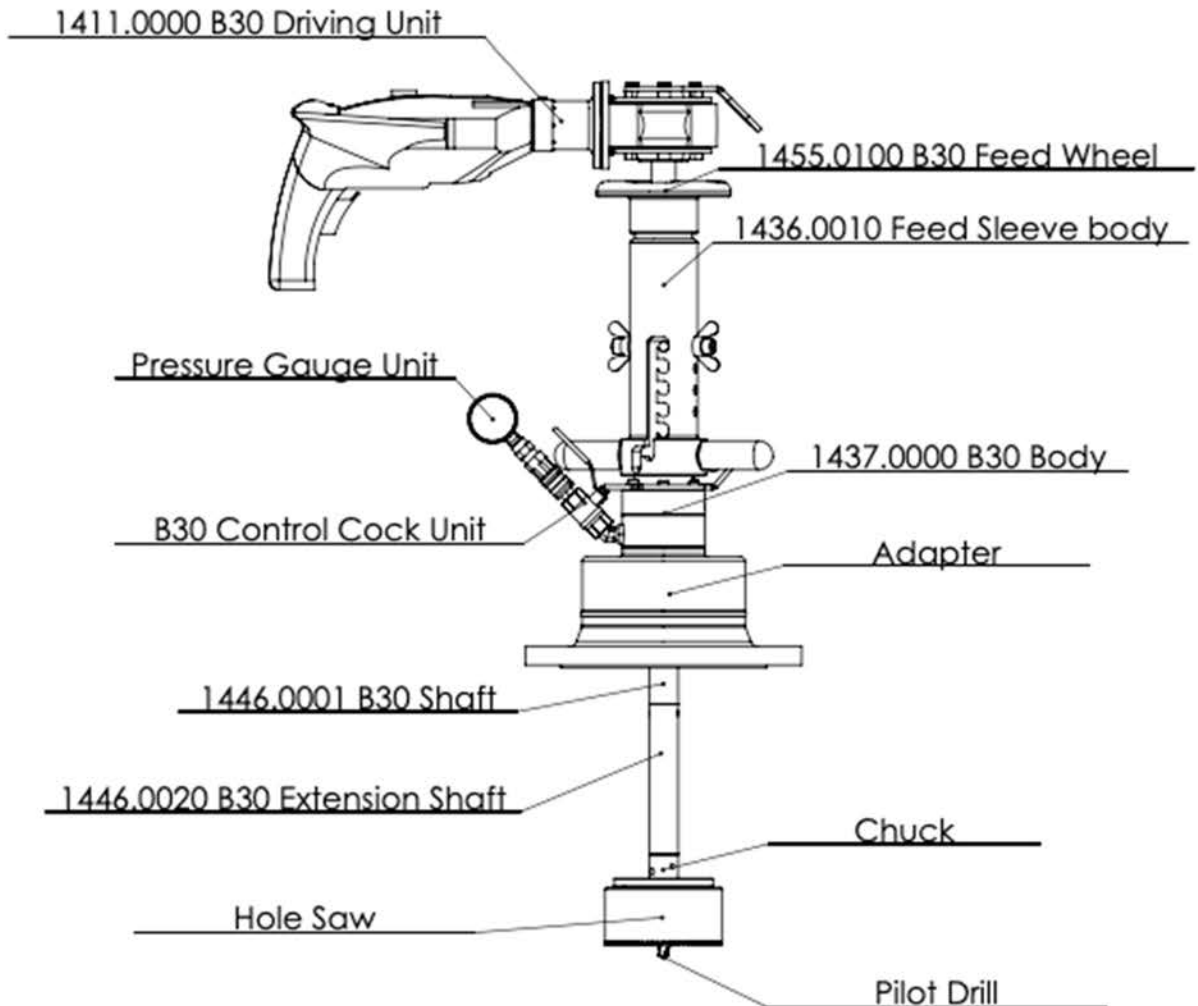



TONISCO B30 – T-FL – SET (NPT & ANSI150)

DN40 (1 1/2") - DN200 (8") Hot tapings

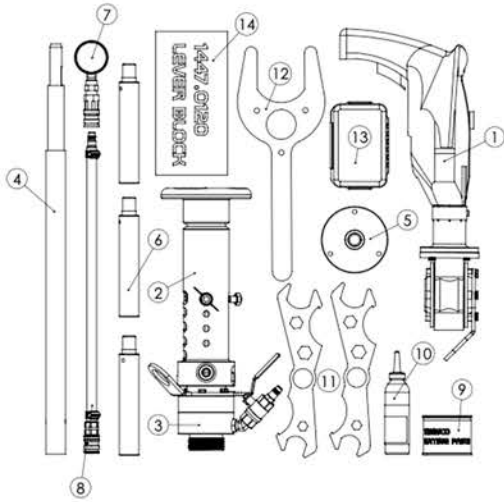

Item	Product Name	Item no.	Qty
Drive Unit	1. Electric Drive B30 Complete	1411.0000	1
Base Unit	2. Feed Device B30, Complete	1455.0000	1
	3. Body B30, complete	1437.0000	1
	4. Base Shaft B30	1446.0001	1
Shaft and Accessories	Gear Fastening Screw	1446.0070	1
	Shaft Extension Socket	1446.0080	1
	Chuck for Hole-Saws < 102 mm	1446.0030	1
	5. Chuck for Hole-saws > 102 mm	1446.0040	1
	Magnet for Jr./B30	1213.0240	1
	Washer	1446.0090	1
	6. Shaft extension B30	1446.0020	3
Pressure Monitoring	7. Pressure Monitoring Set 40bar	1273.0013	1
	8. Pressure Relief Hose W.	1264.0210	1
Center Drills	Pilot Drill B30-HSS Long (120mm)	1446.0050M19	2
	Pilot Drill B30-HSS Normal (100mm)	1446.0060M19	2
Consumables	9. Tonisco Cutting Paste	1289.0010	1
	10. Tonisco Sealant Lubricant	1269.0010	1
Operating tools	11. Tonisco Wrench B30	1450.0170	2
	12. Multi Wrench B30	1450.0150	1
	Allen key 3mm	1250.0010	1
	Allen key 4mm	1213.0110	1
	Allen key 5mm	1250.0020	1
	Shaft Opening Pin Jr./B30	1213.0040	5
	13. Accessory Box B30	1274.0010	1
	14. Shaft Brake B30	1447.0120	1
	Magnet > 45mm	1213.0241	1
	Socket Wrench 1/4"	1450.0041	1
	Socket 13mm 1/4"	1450.0043	1
	Extension 1/4"	1450.0042	1

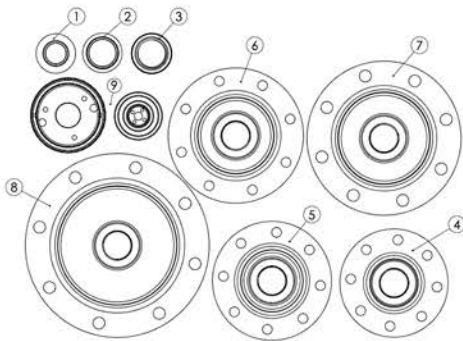

Item	Product Name	Item no.	Qty
Connecting Adapters	1. Adapter NPT 1 1/2"	1239.0400NPT	1
	2. Adapter NPT 2"	1239.0500NPT	1
	3. Adapter NPT 2 1/2"	1239.0650NPT	1
	4. Adapter 3" ANSI #150	1239.0800A150	1
	5. Adapter 4" ANSI #150	1239.1000A150	1
	6. Adapter 5" ANSI #150	1439.1250A150	1
	7. Adapter 6" ANSI #150	1439.1500A150	1
	8. Adapter 8" ANSI #150	1439.2000A150	1
Hole Saws	9. HSS-BiMetal Hole Saws		
	Hole Saw HSS Jr. 38 mm	1219.0380	2
	Hole Saw HSS Jr. 44 mm	1219.0440	2
	Hole Saw HSS Jr. 57 mm	1219.0570	2
	Hole Saw HSS Jr. 76 mm	1219.0760	2
	Hole Saw HSS Jr. 89 mm	1219.0890	2
	Hole Saw HSS B30 121 mm	1619.1210	2
Hole Saw HSS B30 140 mm	1619.1400	2	
Hole Saw HSS B30 180 mm	1619.1800	2	

