

TONISCO® Baby

DN10 (3/8") - DN25 (1") Hot tapplings



DH

DC

PW

WW

HWAC

GAS

PROCESS



Description

The lightweight and robust TONISCO Baby Hot Tap Machine is designed for making connections to pressurized pipelines, tanks, and plant piping.

By using the TONISCO Baby Hot Tap Machine it is possible to make new connections from DN10 (3/8") - DN25 (1"). All the connections can be made without stopping the flow in the main up to 25 bars (360PSI).

The TONISCO Baby Hot Tap Machine is versatile and easy to operate. With suitable adapters, TONISCO Baby can be used with threaded or weldable connections.

All TONISCO Baby Hot Tap Machines provide an effective and ecological way of making connections to mains for repairs, relocations, or additions.

Features

The TONISCO Baby Hot Tap Machine can be used in max. 200°C (390°F) and in pressures up to 25 bar (360PSI). This TONISCO Baby Hot Tap Machine Set comes with a manual drive unit and threaded adapters.

The TONISCO Baby Hot Tap Machine weighs 2,2kg and it can be operated by one person. TONISCO Baby Hot Tap Machine can be used with a wide range of hole saws, pilot drills, and adapters to fit all main materials and substances.

By using TONISCO Baby Hot Tap Machine it is possible to make pipeline alterations without service shutdowns.





TONISCO Baby HOT TAPPING SYSTEM SPECIFICATIONS

Technical Specifications



Hot Tapping Range	DN10-DN25 (3/8" – 1")
Drive Unit Options	<ul style="list-style-type: none"> • Electric 220-240v / 50-60 Hz 1100 VA • Manual
Body Material	CuSn10-C-GC
Feed Unit Material	S355J2
Sealings	EPDM (available also in VITON)
Testing	Pressure test and construction inspection
Pressure Test	37,5bar
Max. Operational Pressure	25bar
Max. Operational Temperature	160°C (200°C with Viton sealings)
Weight of the machine	2,2 kg (Total set 7,00 kg)
Working mediums:	Water, Steam, Gas and other substances*
*See specifications of the sealing manufacturer	

TONISCO Baby HOT TAP MACHINE - TYPICAL SET UP

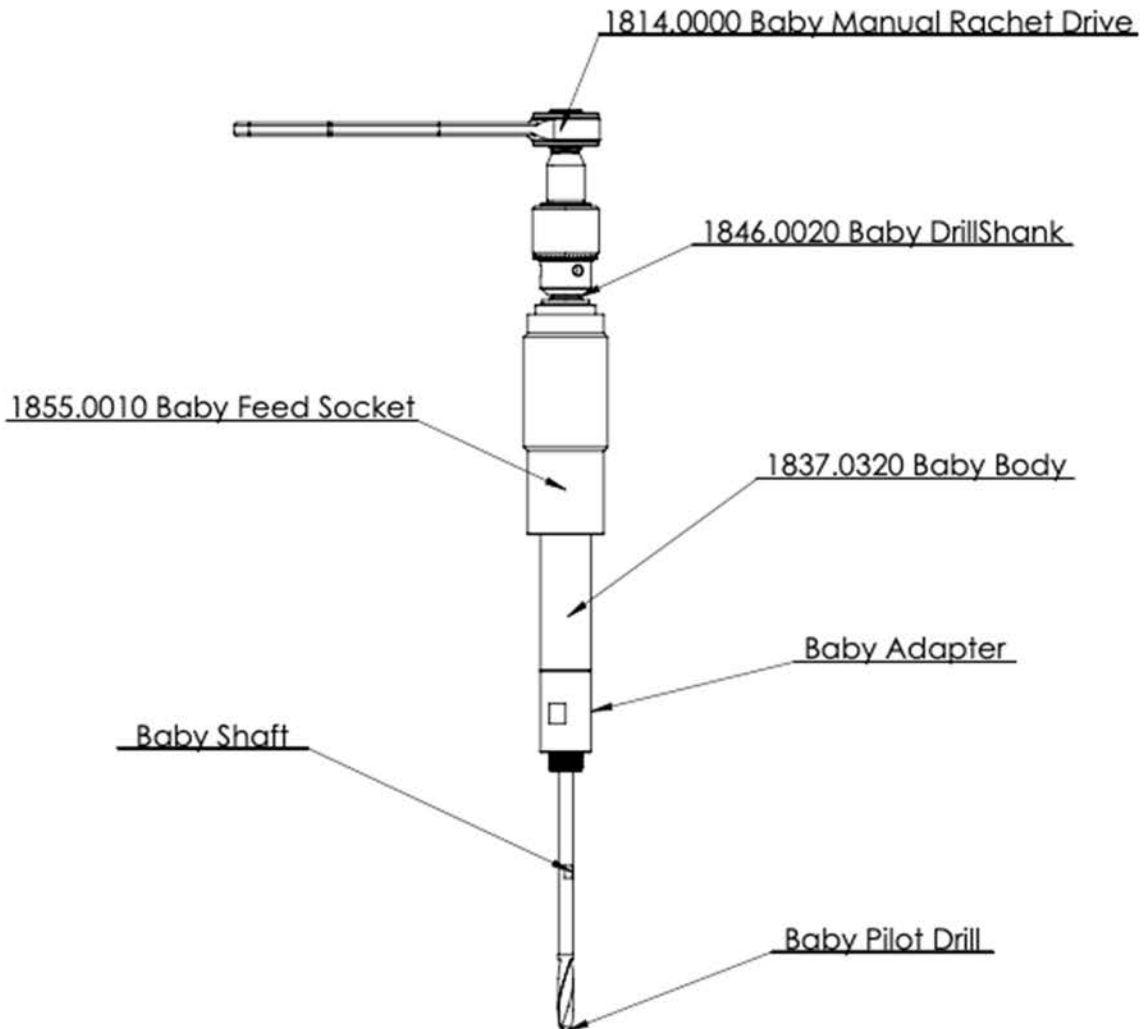



TONISCO Baby – T – SET (NPT)

DN10 (3/8") - DN25 (1") Hot tapings

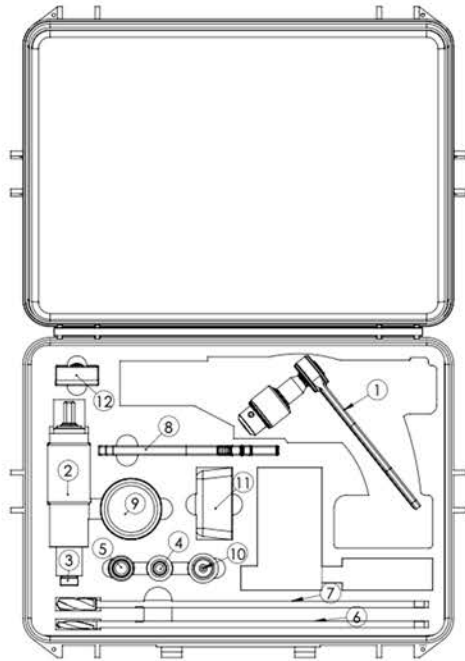

Item	Product Name	Item no.	Qty	
Drive Unit	1. Baby Manual Ratchet Drive	1814.0000	1	
Base Unit	2. Baby Feed Unit	1855.0010	1	
	3. Baby Body Unit	1837.0020	1	
Adapters	4. Baby adapter DN10	1837.0351	1	
	11. O-ring adapter DN10	1837.0460	1	
	5. Baby adapter DN15	1837.0352	1	
	11. O-ring adapter DN15	1837.0450	1	
	11. Baby adapter DN20	1837.0363	1	
	11. Baby adapter DN25	1837.0369	1	
	11. Adapter 20 sealing	1837.0470	1	
	11. Adapter 15 sealing	1837.0480	1	
	11. Adapter 10 sealing	1837.0490	1	
	Drills	6. Drill DN10/9 (450 mm)	1846.0409	1
		6. Drill DN10/9 (390 mm)	1846.0509	1
7. Drill DN 20/13 (450 mm)		1846.0413	1	
7. Drill DN 20/13 (390 mm)		1846.0513	1	
Tools	8. Adj. wrench	1850.0010	1	
	11. Shaft wrench 7mm	1837.0500	1	
	11. L-wrench 3mm	1213.0110	1	
	9. Cutting Paste	1289.0010	1	
	10. Tonisco sealant	1269.0010	1	
	11. Accessory box Baby	1274.0010	1	
	12. Pressure gauge	1664.0000	1	
	11. Pressure test adapter	1664.0001	1	
Transport	Transport Box	1827.0010	1	