

TONISCO[®] B40

DN100 (4") - DN500 (20") Hot tapplings



DH

DC

HVAC

PROCESS

Description

The lightweight and robust TONISCO B40 Hot Tap Machine Set is designed for making connections to pipelines, tanks, and plant piping.

By using the TONISCO B40 Hot Tap Machine Set it is possible to make new connections from DN100 (4") - DN500 (20"). All the connections can be made without stopping the flow in the main up to 40 bars (580PSI).

The TONISCO B40 Hot Tap Machine is versatile and easy to operate. With suitable adapters TONISCO B40 can be used for flanged, threaded, or weldable connections.

All TONISCO B40 Hot Tap Machines provide an effective and ecological way of making connections to mains for repairs, relocations, or additions.

Features

The TONISCO B40 Hot Tap Machine can be used in max. 200°C (390°F) and in pressure up to 40 bar (580PSI). This TONISCO B40 Hot Tap Machine Set is equipped with an electric drive unit and flanged adapters.

TONISCO B40 Hot Tap Machine weighs 25,5kg and it can be operated by two people. TONISCO B40 Hot Tap Machine can be used with a wide range of hole saws, pilot drills, and adapters to fit all main materials and substances.

By using TONISCO B40 Hot Tap Machine it is possible to make pipeline alterations without shutdowns.



TONISCO® B40

Hot tapping machine



TONISCO B40 HOT TAPPING SYSTEM SPECIFICATIONS



Technical Specifications

Hot Tapping Range	DN100-DN500 (4" – 20")
Drive Unit Options	<ul style="list-style-type: none">• Electric 220-230v / 50-60 Hz 1700W• Pneumatic 6-8bar / 1800l/min• Hydraulic 30-50l/min 140bar• Manual
Body Material	AISI10Mg
Feed Unit Material	AISI10Mg
Sealings	EPDM (VITON)
Testing	Pressure test and construction inspection
Pressure Test	37bar (60 bar with high pressure model)
Max. Operational Pressure	25bar (40 bar with high pressure model)
Max. Operational Temperature	+160°C (+200°C with Viton sealings)

TONISCO B40 HOT TAP MACHINE - TYPICAL SET UP

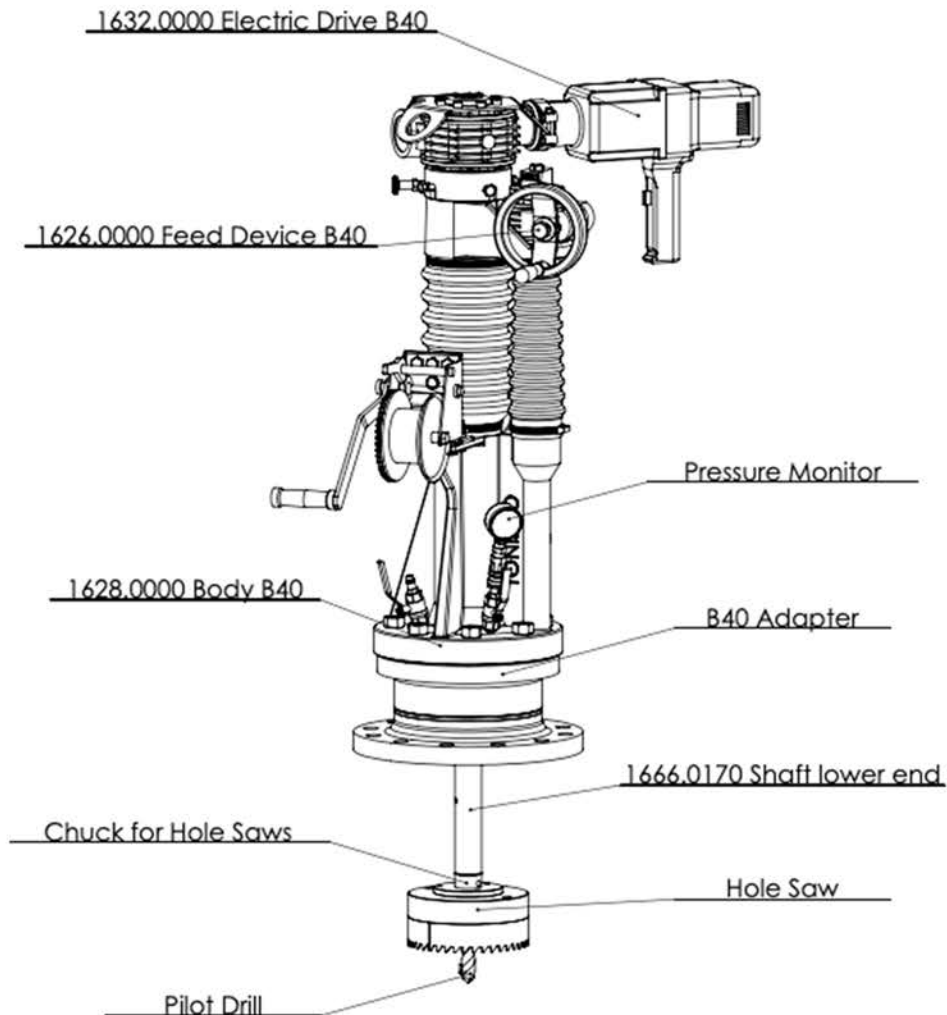



TONISCO B40 – FL – SET (ANSI150)

DN100 (4") - DN500 (20") Hot tapings

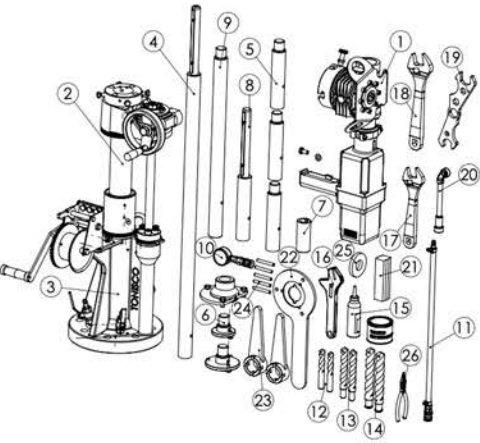

Item	Product Name	Item no.	Qty
Drive Unit	1. Electric Drive B40 Complete	1632.0000	1
Base Unit	2. Feed Device B40, Complete	1626.0000	1
	3. Body B40, complete	1628.0000	1
Shaft and Accessories	4. Base shaft 710/930 mm	1666.0010	1
	5. Shaft extension B40 180 mm	1666.0050	3
	Shaft screw, normal	1666.0030	1
	Shaft washer B40	1666.0040	1
	6. Chuck < 110 mm	1666.0080	1
	6. Chuck > 110 mm	1666.0070	1
	7. Shaft adjusting socket, normal	1666.0130	1
	8. Shaft upper end complete	1666.0160	1
	9. Shaft lower end	1666.0170	1
	6. Chuck > 275 mm	1666.0200	1
	Pressure Monitoring	10. Pressure Monitor Set	1273.0000
11. Pressure Relief Hose W.		1264.0210	1
Center Drills	12. HSS Pilot drill Ø16mm	1666.0100	2
	13. HSS Pilot drill Ø20mm	1666.0110	2
	14. Central Drill 25mm	1666.0106	2
	Retainer ring (Pilot drill 25 mm)	1666.0109	1
Consumables	15. Tonisco Sealant Lubricant	1269.0010	1
Operating tools	16. Adjusting wrench	1200.2106	1
	17. Wrench 30 mm	1450.0070	2
	18. Wrench 36 mm	1650.0360	2
	19. Tonisco Wrench B30	1450.0170	1
	20. Pipe wrench 13 mm	1450.0050	1
	21. Allen key set 2,5-10 mm	1250.0080	1
	22. Chuck Opener B40	1650.0020	1
	23. Shaft Opener B40	1650.0030	2
	24. Shaft opening pin B40	1650.0040	5
	25. Magnet > 75 mm	1213.0242	1
	26. Seeger Pliers	1650.0050	1

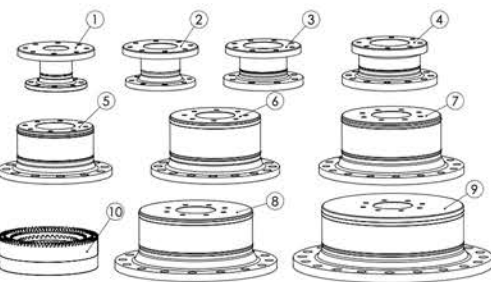

Item	Product Name	Item no.	Qty
Connecting Adapters According to: ANSI B16.5 Class 150	Adapter 4" ANSI #150	1643.1000	1
	Adapter 5" ANSI #150	1643.1250	1
	Adapter 6" ANSI #150	1643.1500	1
	Adapter 8" ANSI #150	1643.2000	1
	Adapter 10" ANSI #150	1643.2500	1
	Adapter 12" ANSI #150	1643.3000	1
	Adapter 14" ANSI #150	1643.3500	1
	Adapter 16" ANSI #150	1643.4000	1
	Adapter 20" ANSI #150	1643.5000	1
	HSS-BiMetal Hole Saws	H-saw HSS 95 mm / B40	1619.0950
H-saw HSS 121 mm / B40		1619.1210	2
H-saw HSS 140 mm / B40		1619.1400	2
H-saw HSS 180 mm / B40		1619.1800	2
H-saw HSS 220 mm / B40		1619.2200	2
H-saw HSS 270 mm / B40		1619.2700	2
H-saw HSS 320 mm / B40		1619.3200	2
H-saw HSS 355 mm / B40		1619.3550	2
H-saw HSS 404 mm / B40		1619.4040	2

