

TONISCO[®] Jr.

DN20 (3/4") - DN100 (4") Hot tapplings



DH

DC

HVAC

PROCESS

Description

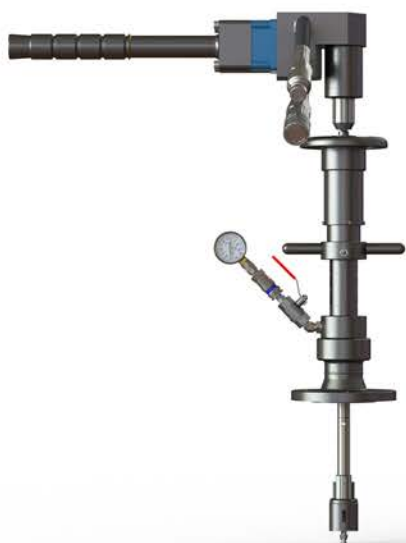

The lightweight and robust TONISCO Jr. Hot Tap Machine Set is designed for making connections to pipelines, tanks, and plant piping.

By using the TONISCO Jr. Hot Tap Machine Set it is possible to make new connections from DN20 (3/4") - DN100 (4"). All the connections can be made without stopping the flow in the main up to 60 bars (900PSI).

The TONISCO Jr. Hot Tap Machine is versatile and easy to operate. With suitable adapters TONISCO Jr. can be used for flanged, threaded, or weldable connections.

All TONISCO Jr. Hot Tap Machines provide an effective and ecological way of making connections to mains for repairs, relocations, or additions.

Features

The TONISCO Jr. Hot Tap Machine can be used in max. 200°C (390°F) and in pressure up to 60 bar (900PSI). This TONISCO Jr. Hot Tap Machine Set is equipped with a hydraulic drive unit and flanged adapters.

TONISCO Jr. Hot Tap Machine weighs 5,5kg and it can be operated by one person. TONISCO Jr. Hot Tap Machine can be used with a wide range of hole saws, pilot drills, and adapters to fit all main materials and substances.

By using TONISCO Jr. Hot Tap Machine it is possible to make pipeline alterations without shutdowns. The system has technical approval from the German quality organization TÜV-Nord. The certificate is valid for the whole range from DN20 (3/4") - DN100 (4").





TONISCO Jr. HOT TAPPING SYSTEM SPECIFICATIONS



Technical Specifications

Hot Tapping Range	DN20-DN100 (3/4" – 4")
Drive Unit Options	<ul style="list-style-type: none"> • Electric 220-240v / 50-60 Hz 1300W • Pneumatic 6-7bar / 1500 l/min • Hydraulic 15-30l/min 140 bar • Manual
Body Material	42CrMo4
Feed Unit Material	S355J2
Sealings	EPDM (NBR & VITON)
Testing	Pressure test and construction inspection
Pressure Test	60bar
Max. Operational Pressure	40bar
Max. Operational Temperature	-0°C +200°C

TÜV-certificate number: TÜV.A. 366-16

TONISCO Jr. HOT TAP MACHINE - TYPICAL SET UP

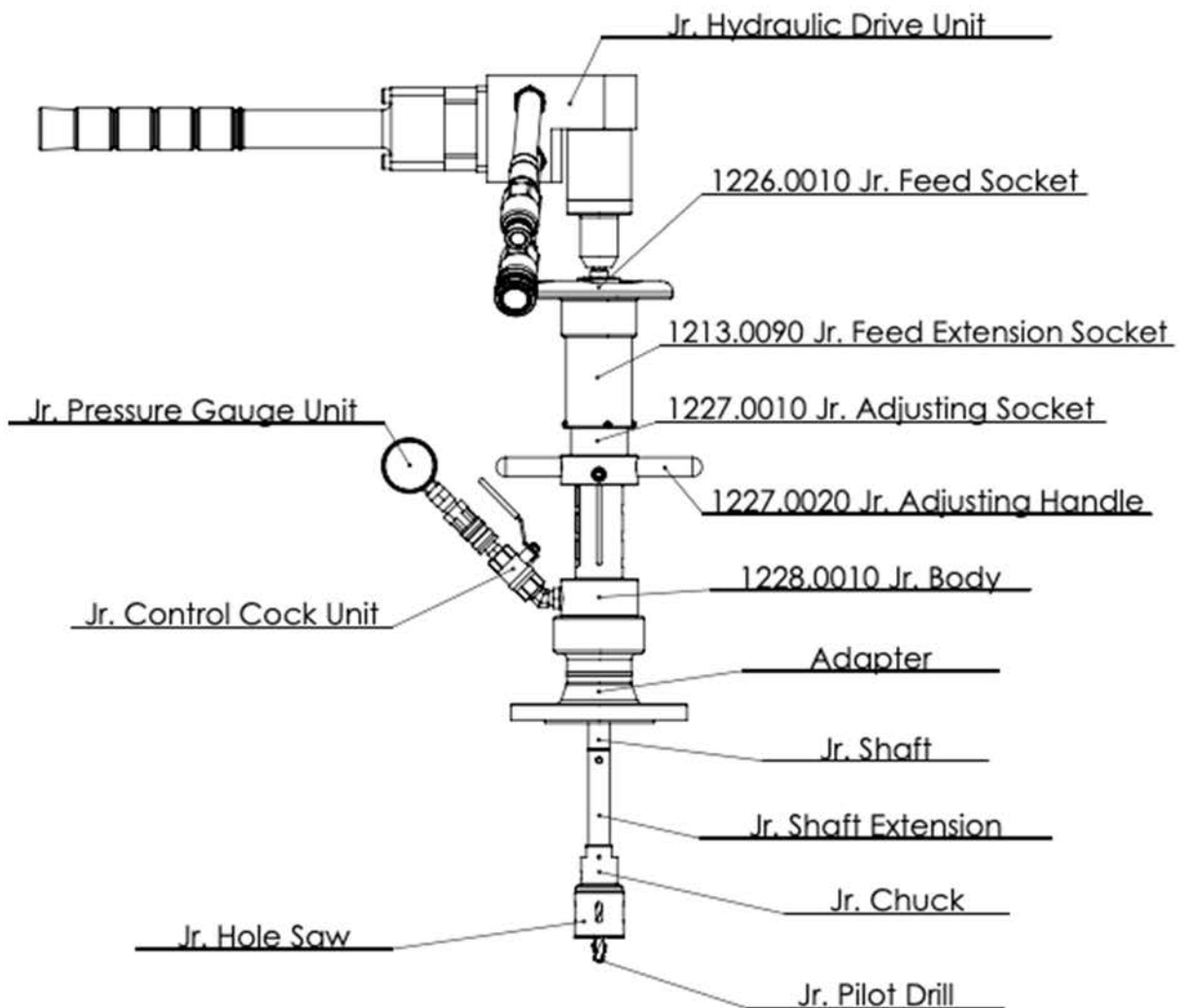



TONISCO Jr. – FL – SET (ANSI150)

DN20 (3/4") - DN100 (4") Hot tapplings

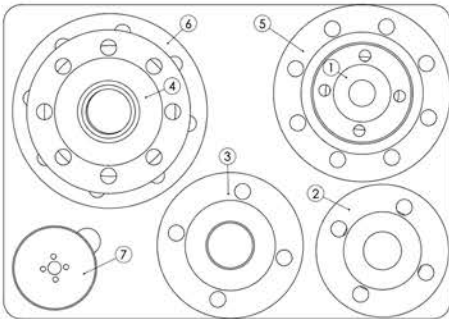
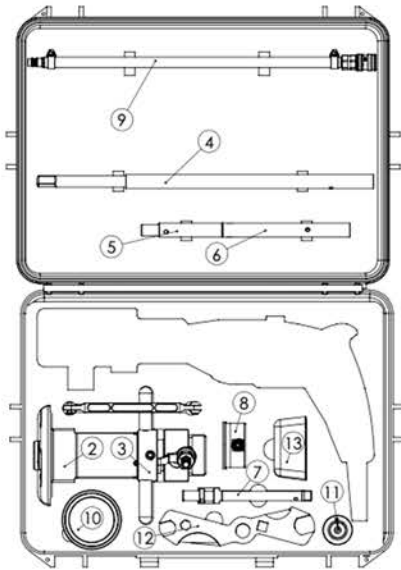
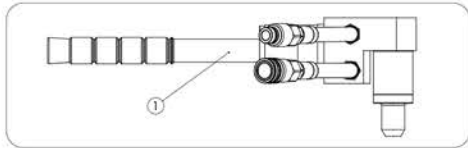

Item	Product Name	Item no.	Qty
Drive Unit	1. Hydraulic Drive Jr. Complete	1267.0000HD	1
Base Unit	2. Feed Device Jr. Complete	1226.0000	1
	3. Body Jr. Complete	1228.0000	1
Shaft and Accessories	4. Drill Shaft 350/475 mm	1213.0010	1
	Gear Fastening Screw	1213.0100	1
	Shaft Extension Socket	1213.0090	1
	Chuck for Hole-Saws < 30 mm	1213.0070	1
	Chuck for Hole-saws > 30 mm	1213.0060	1
	Magnet for Jr./B30	1213.0240	1
	5. Extension shaft 180 mm	1213.0020	1
Pressure Monitoring	6. Extension 90 mm	1213.0030	1
	7. DN20 Special shaft	1213.0120	1
	8. Pressure Monitor Set 40 bar	1273.0013	1
Center Drills	9. Pressure Relief Hose W.	1264.0210	1
	Pilot Drill Jr-HSS normal (95mm)	1213.0080M19	2
Consumables	Pilot Drill Jr-HSS short (83mm)	1213.0082M19	1
	10. Tonisco Cutting Paste	1289.0010	1
Operating tools	11. Tonisco Sealant Lubricant	1269.0010	1
	12. Tonisco wrench	1250.0170	2
	Allen key 3 mm	1250.0010	1
	Allen key 4 mm	1213.0110	1
	Allen key 5 mm	1250.0020	1
	Shaft opening pin Jr./B30	1213.0040	5
	13. Accessory box Jr.	1274.0010	1

Item	Product Name	Item no.	Qty
Connecting Adapters	1. Adapter 1" / 1 ¼" ANSI #150	1239.0250	1
	2. Adapter 1 ½" ANSI #150	1239.0400A150	1
	3. Adapter 2" ANSI #150	1239.0500A150	1
	4. Adapter 2 ½" ANSI #150	1239.0650A150	1
	5. Adapter 3" ANSI #150	1239.0800A150	1
	6. Adapter 4" ANSI #150	1239.1000A150	1
Hole Saws	8. HSS-BiMetal Hole Saws		
	Hole Saw HSS Jr. 19 mm	1219.0190	2
	Hole Saw HSS Jr. 24 mm	1219.0240	2
	Hole Saw HSS Jr. 30 mm	1219.0300	2
	Hole Saw HSS Jr. 38 mm	1219.0380	2
	Hole Saw HSS Jr. 44 mm	1219.0440	2
	Hole Saw HSS Jr. 57 mm	1219.0570	2
	Hole Saw HSS Jr. 76 mm	1219.0760	2
Hole Saw HSS Jr. 89 mm	1219.0890	2	