

DH

DC

HVAC

PROCESS

## Description



The lightweight and robust TONISCO Jr. Hot Tap Machine Set is designed for making connections to pipelines, tanks, and plant piping through Tonisco hot tap valves.

By using the TONISCO Jr. Hot Tap Machine Set it is possible to make new connections from DN20 (3/4") - DN100 (4"). All the connections can be made without stopping the flow in the main up to 60 bars (900PSI).

The TONISCO Jr. Hot Tap Machine is versatile and easy to operate. With suitable adapters TONISCO Jr. can be used for flanged, threaded, or weldable connections.

All TONISCO Jr. Hot Tap Machines provide an effective and ecological way of making connections to mains for repairs, relocations, or additions.

## Features

The TONISCO Jr. Hot Tap Machine can be used in max. 200°C (390°F) and in pressure up to 60 bar (900PSI). This TONISCO Jr. Hot Tap Machine Set is equipped with an electric drive unit and weldable-threaded Tonisco adapters.

TONISCO Jr. Hot Tap Machine weighs 5,5kg and it can be operated by one person. TONISCO Jr. Hot Tap Machine can be used with a wide range of hole saws, pilot drills, and adapters to fit all main materials and substances.

By using TONISCO Jr. Hot Tap Machine it is possible to make pipeline alterations without shutdowns. The system has technical approval from the German quality organization TÜV-Nord. The certificate is valid for the whole range from DN20 (3/4") - DN100 (4").



# TONISCO Jr. HOT TAPPING SYSTEM SPECIFICATIONS



## Technical Specifications

Hot Tapping Range	DN20-DN100 (3/4" – 4")
Drive Unit Options	<ul style="list-style-type: none"> <li>• Electric 220-240v / 50-60 Hz 1300W</li> <li>• Pneumatic 6-7bar / 1500 l/min</li> <li>• Hydraulic 15-30l/min 140 bar</li> <li>• Manual</li> </ul>
Body Material	42CrMo4
Feed Unit Material	S355J2
Sealings	EPDM (NBR & VITON)
Testing	Pressure test and construction inspection
Pressure Test	60bar
Max. Operational Pressure	40bar
Max. Operational Temperature	-0°C +200°C

TÜV-certificate number: TÜV.A. 366-16

## TONISCO Jr. HOT TAP MACHINE - TYPICAL SET UP

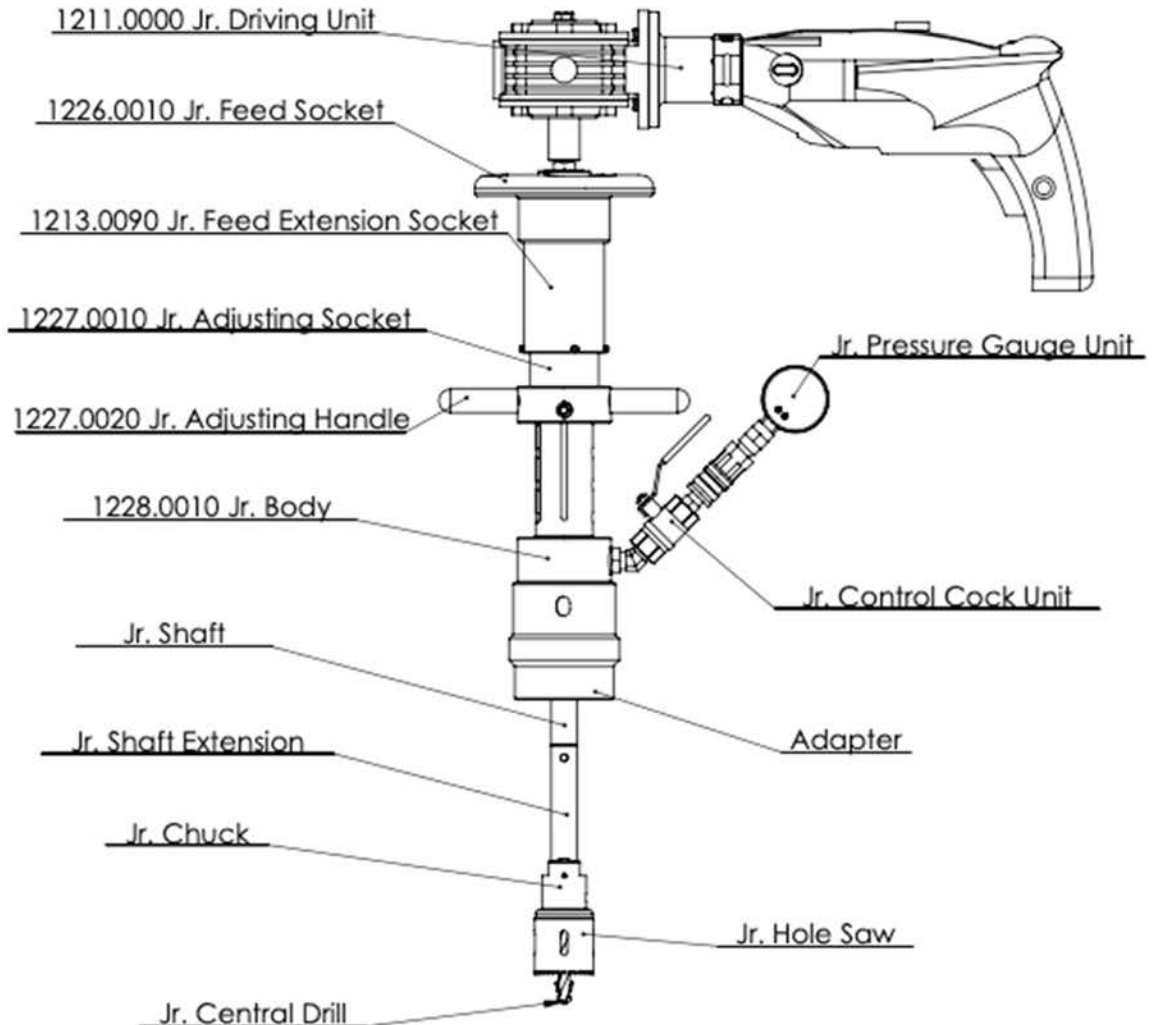



# TONISCO Jr. – WT – GOLD LINE SET

DN20 (3/4") - DN100 (4") Hot tapings

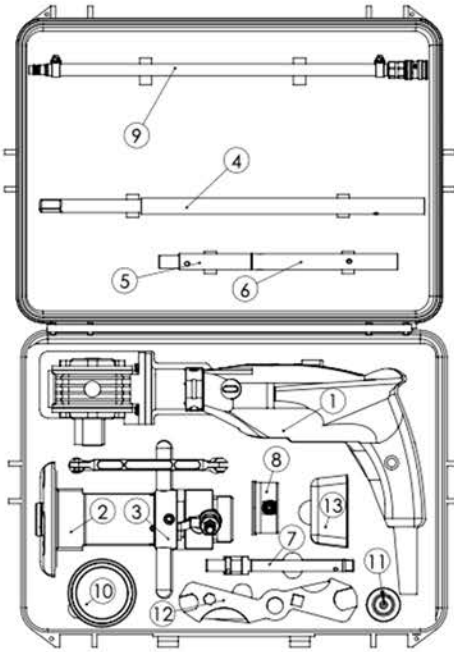

Item	Product Name	Item no.	Qty
Drive Unit	1. Electric Drive Jr. Complete	1211.0000	1
Base Unit	2. Feed Device Jr. Complete	1226.0000	1
	3. Body Jr. Complete	1228.0000	1
	4. Drill Shaft 350/475 mm	1213.0010	1
Shaft and Accessories	Gear Fastening Screw	1213.0100	1
	Shaft Extension Socket	1213.0090	1
	Chuck for Hole-Saws < 30 mm	1213.0070	1
	Chuck for Hole-saws > 30 mm	1213.0060	1
	Magnet for Jr./B30	1213.0240	1
	5. Extension shaft 180 mm	1213.0020	1
	6. Extension 90 mm	1213.0030	1
	7. DN20 Special shaft	1213.0120	1
Pressure Monitoring	8. Pressure Monitor Set 40 bar	1273.0013	1
	9. Pressure Relief Hose W.	1264.0210	1
Center Drills	Pilot Drill Jr-HSS normal (95mm)	1213.0080M19	2
	Pilot Drill Jr-HSS short (83mm)	1213.0082M19	1
Consumables	10. Tonisco Cutting Paste	1289.0010	1
	11. Tonisco Sealant Lubricant	1269.0010	1
Operating tools	12. Tonisco wrench	1250.0170	2
	Allen key 3 mm	1250.0010	1
	Allen key 4 mm	1213.0110	1
	Allen key 5 mm	1250.0020	1
	Shaft opening pin Jr./B30	1213.0040	5
	13. Accessory box Jr.	1274.0010	1

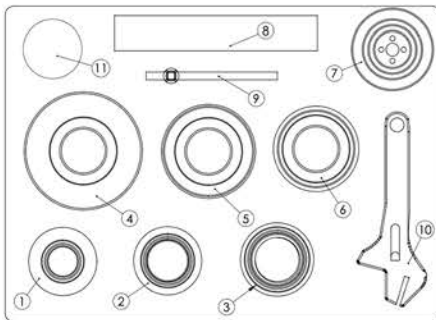

Item	Product Name	Item no.	Qty
Connecting Adapters	1. Adapter DN20/25	1218.0250	1
	2. Adapter DN32/40	1218.0400	1
	3. Adapter DN50	1218.0500	1
	4. Adapter DN65	1218.0650	1
	5. Adapter DN80	1218.0800	1
	6. Adapter DN100	1218.1000	1
Hole Saws	7. Hole Saw HSS Jr. 19 mm	1219.0190	2
	7. Hole Saw HSS Jr. 24 mm	1219.0240	2
	7. Hole Saw HSS Jr. 30 mm	1219.0300	2
	7. Hole Saw HSS Jr. 38 mm	1219.0380	2
	7. Hole Saw HSS Jr. 44 mm	1219.0440	2
	7. Hole Saw HSS Jr. 57 mm	1219.0570	2
	7. Hole Saw HSS Jr. 70 mm	1219.0700	2
	7. Hole Saw HSS Jr. 95 mm	1219.0950	2
Operational Tools	8. Socket set 3/8"	1200.2105	1
	9. T-key 3/8"	1200.2107	1
	10. Wrench P (41 mm)	1200.2106	1
Center Drills	11. Accessory box	1274.0020	1
	Pilot Drill Jr-HM normal (95mm)	1213.0080M19	2
	Pilot Drill Jr-HM short (83mm)	1213.0082M19	1
	Spare Sealing Set		1