

TONISCO[®] Jr.

DN20 (3/4") - DN100 (4") High Pressure Hot tapplings



PROCESS

Description



The lightweight and robust TONISCO Jr. Hot Tap Machine Set is designed for making connections to high pressure process industry pipelines, tanks, and plant piping.

By using the TONISCO Jr. Hot Tap Machine Set it is possible to make new connections from DN20 (3/4") - DN100 (4"). All the connections can be made without stopping the flow in the main up to 60 bars (900PSI).

The TONISCO Jr. Hot Tap Machine is versatile and easy to operate. With suitable adapters TONISCO Jr. can be used for flanged, threaded, or weldable connections.

All TONISCO Jr. Hot Tap Machines provide an effective and ecological way of making connections to mains for repairs, relocations, or additions.

Features

The TONISCO Jr. Hot Tap Machine can be used in max. 200°C (390°F) and in pressure up to 60 bar (900PSI). This high pressure TONISCO Jr. Hot Tap Machine Set is equipped with a manual drive unit and flanged adapters.

TONISCO Jr. Hot Tap Machine weighs 5,5kg and it can be operated by one person. TONISCO Jr. Hot Tap Machine can be used with a wide range of hole saws, pilot drills, and adapters to fit all main materials and substances.





TONISCO Jr. High Pressure HOT TAPPING SYSTEM SPECIFICATIONS



Technical Specifications

Hot Tapping Range	DN20-DN100 (3/4" – 4")
Drive Unit Options	<ul style="list-style-type: none"> • Electric 220-240v / 50-60 Hz 1300W • Pneumatic 6-7bar / 1500 l/min • Hydraulic 15-30l/min 140 bar • Manual
Body Material	42CrMo4
Feed Unit Material	S355J2
Sealings	EPDM (NBR & VITON)
Testing	Pressure test and construction inspection
Pressure Test	90bar
Max. Operational Pressure	60bar
Max. Operational Temperature	-0°C +200°C

TONISCO Jr. HOT TAP MACHINE - TYPICAL SET UP

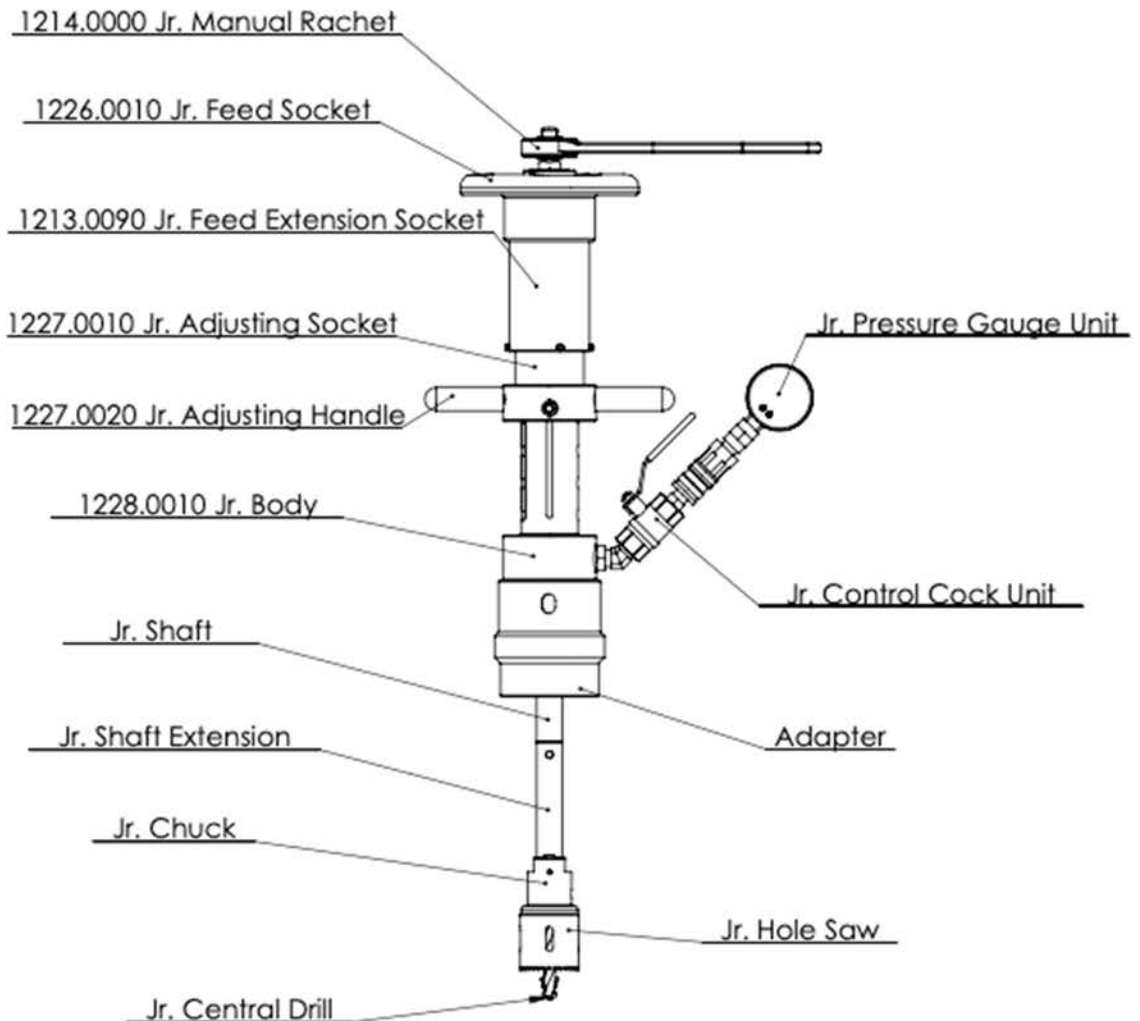



TONISCO Jr. – FL – SET (PN63)

DN20 (3/4") - DN100 (4") High Pressure Hot tapping

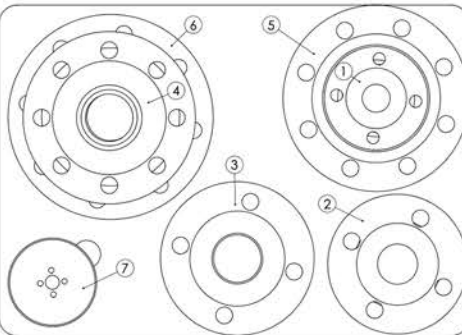
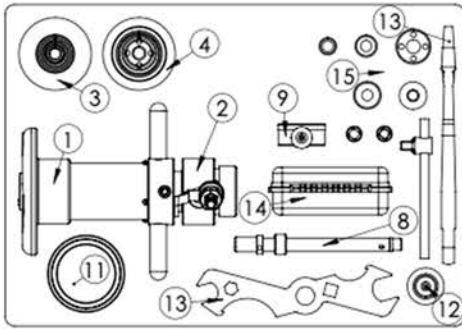
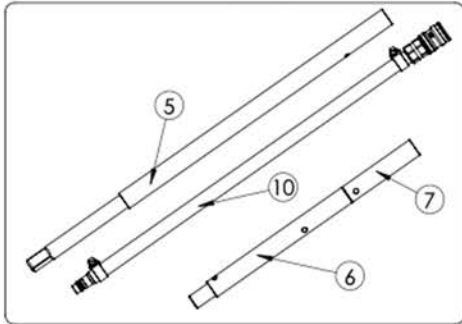

Item	Product Name	Item no.	Qty	
Drive Unit	1. Manual Ratchet Drive Jr.	1214.0000HP	1	
Base Unit	2. Feed Device Jr. Complete	1226.0000HP	1	
	3. Body Jr. Complete	1228.0000HP	1	
	4. Drill Shaft 350/475 mm	1213.0010	1	
Shaft and Accessories	4. Drill Shaft 650/775 mm	1229.0040	1	
	Gear Fastening Screw	1213.0100	1	
	Shaft Extension Socket	1213.0090	1	
	Chuck for Hole-Saws < 30 mm	1213.0070	1	
	Chuck for Hole-saws > 30 mm	1213.0060	1	
	Magnet for Jr./B30	1213.0240	1	
	5. Extension shaft 180 mm	1213.0020	1	
	6. Extension 90 mm	1213.0030	1	
	7. DN20 Special shaft	1213.0120	1	
	Pressure Monitoring	8. Pressure Monitor Set 100 bar	1273.0012HP	1
		9. Pressure Relief Hose W.	1264.0210	1
	Center Drills	Pilot Drill Jr-HSS normal (95mm)	1213.0080M19	2
		Pilot Drill Jr-HSS short (83mm)	1213.0082M19	1
Consumables	10. Tonisco Cutting Paste	1289.0010	1	
	11. Tonisco Sealant Lubricant	1269.0010	1	
Operating tools	12. Tonisco wrench	1250.0170	2	
	Allen key 3 mm	1250.0010	1	
	Allen key 4 mm	1213.0110	1	
	Allen key 5 mm	1250.0020	1	
	Shaft opening pin Jr./B30	1213.0040	5	
	13. Accessory box Jr.	1274.0010	1	

Item	Product Name	Item no.	Qty
Connecting Adapters	1. Adapter DN25 PN63	1239.0250FL63	1
	2. Adapter DN32 PN 63	1239.0320FL63	1
	3. Adapter DN40 PN63	1239.0400FL63	1
	4. Adapter DN50 PN63	1239.0500FL63	1
	5. Adapter DN65 PN63	1239.0650FL63	1
	6. Adapter DN80 PN63	1239.0800FL63	1
	7. Adapter DN100 PN63	1239.1000FL63	1
Hole Saws	8. HSS-BiMetal Hole Saws		
	Hole Saw HSS Jr. 19 mm	1219.0190	2
	Hole Saw HSS Jr. 24 mm	1219.0240	2
	Hole Saw HSS Jr. 30 mm	1219.0300	2
	Hole Saw HSS Jr. 38 mm	1219.0380	2
	Hole Saw HSS Jr. 44 mm	1219.0440	2
	Hole Saw HSS Jr. 57 mm	1219.0570	2
Hole Saw HSS Jr. 76 mm	1219.0760	2	
Transport Suitcase		1272.0010	1